



**PumpSmart PS200
Drive Dimensions and Ratings
Frame R2-IP21**

PUMPSMART

PumpSmart PS200 Pump and Motor Control System

The PumpSmart PS200 is a pump and motor control system that provides integral starting, right-sizing, pump protection and process control for all pumping applications. The PumpSmart PS200 is based upon the ABB ACS800 variable frequency drive platform. PumpSmart Control Solutions has worked with ABB to incorporate proprietary pump protection, process control and configuration algorithms into the drive to make it more suitable for pumping applications

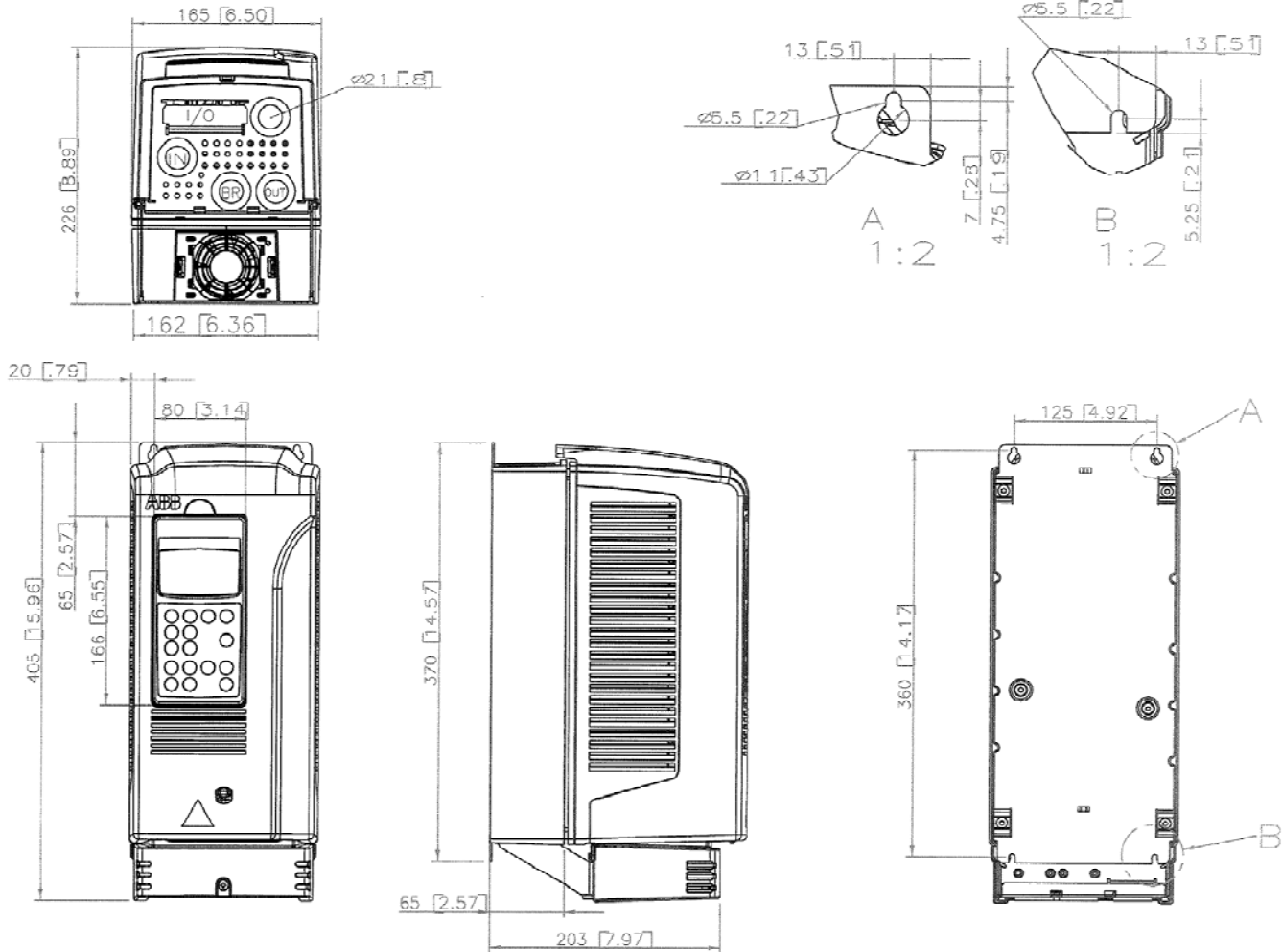

Drive Dimensions

Frame	Height mm [inches]	Width mm [inches]	Depth mm [inches]	Weight kg [lbm]
R2	405 [15.94]	165 [6.5]	226 [8.89]	9 [20]

*Dimensions not for construction



PumpSmart PS200 Drive Dimensions and Ratings Frame R2-IP21

PUMPSMART

Drive Ratings

ITT Type Code	Input Voltage VAC	Power P _N ¹ KW	Nominal Current I _{2N} ² Amps	Heat Dissipation Watts	Air Flow M ³ /Hr	Noise Level dBA	Frame	Enclosure Rating	Recommended Main Fuses		
									gG or aR	V	IEC Size
ACS-ITT-01-0001-2	230	0.75	4.7	100	35	62	R2	IP21	10	500	000
ACS-ITT-01-0002-2	230	1.1	6	100					10		
ACS-ITT-01-0003-2	230	1.5	7.7	100					10		
ACS-ITT-01-0004-2	230	2.2	10.2	120					16		
ACS-ITT-01-0005-2	230	3	12.7	140					16		
ACS-ITT-01-0003-3	400	1.5	4.7	100					10		
ACS-ITT-01-0004-3	400	2.2	5.9	120					10		
ACS-ITT-01-0005-3	400	3	7.7	140					10		
ACS-ITT-01-0006-3	400	4	10.2	160					16		
ACS-ITT-01-0009-3	400	5.5	12.7	200					16		
ACS-ITT-01-0004-5	500	2.2	4.5	120					10		
ACS-ITT-01-0005-5	500	3	5.6	140					10		
ACS-ITT-01-0006-5	500	4	7.7	160					10		
ACS-ITT-01-0009-5	500	5.5	10	200					16		
ACS-ITT-01-0011-5	500	7.5	12	250					16		

¹ P_N - Nominal Power Rating at listed voltage rating for variable torque loads
² I_{2N} - Continuous base current with 10% overload for 1 min / 5 minutes at 40° C

Frame Size	U1/V1/W1 - U2/V2/W2 R+, R- Terminals			Earthing PE Terminal	
	Max. Wire Size	Max. Cable Dia.	Torque	Max. Wire Size	Torque
	mm ²	mm	Nm	mm ²	Nm
R 2	16*	21	1.2-1.5	10	1.5

*16 mm² rigid solid cable 10 mm² flexible stranded cable

Power Cabling Schematic

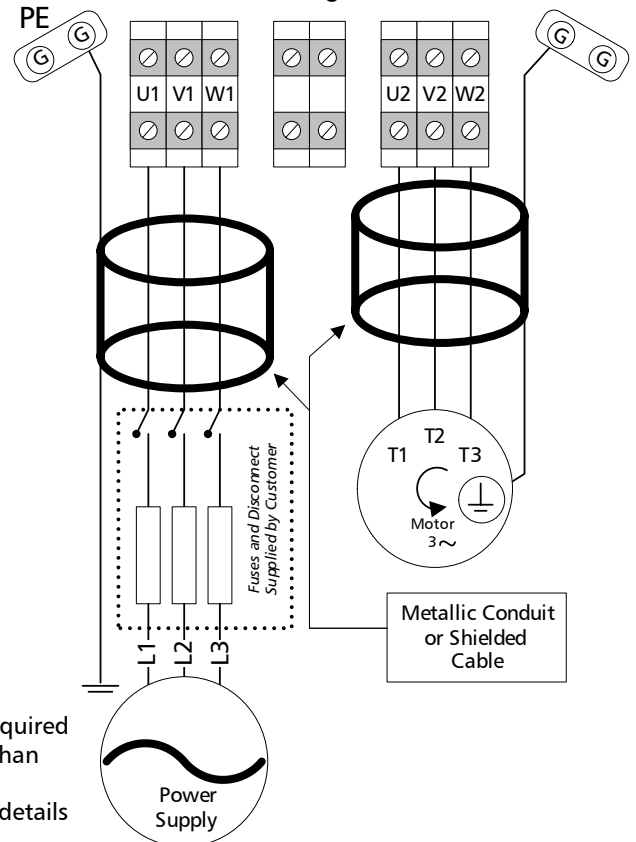

General Notes:

- 1- 360° Grounded terminations are required
 2. Fuse operating time must be less than 0.5 seconds to protect drive.
- Refer to Technical Data section for details



PumpSmart PS200
Drive Dimensions and Ratings
Frame R2-IP21

PUMPSMART

PumpSmart® PS200

Drive Hardware: ABB ACS800 -6 Pulse PWM

CERTIFICATIONS

<u>USA/Canada</u> 600 VAC and Below UL, C-UL, CSA	<u>Europe</u> CE Marked Bureau Veritas Cert 14370/AO BV EMC 89/336/EEC as amended by 93/68 DNV Cert. E-7039
---	---

2 Current Analog Output.....	4...20mA 700Ω Max load impedance 10 bit resolution Galvanically isolated as a group
------------------------------	--

INPUT POWER

Voltage.....	208..690 VAC 3 Phase ±10%
Overload.....	110% for 1 min/5 min, 140-150% for 10 sec at startup
Frequency.....	48...63Hz

Digital Inputs (7).....	2 Wire Start/Stop Hand-off Auto (HOA) 3-Wire Start/Stop Setpoint 1-2 Speed Override Specific Gravity Secondary Protect A/B Digital Reset E Stop/Permissive Motor Thermistor 24 VDC Input Voltage 1 mS filtering time
-------------------------	---

Fundamental Power.....	COSΦ ₁ = 0.98 (fundamental)
Factor (COSΦ ₁)	COSΦ ₁ = 0.93...95 (total)
Efficiency.....	98% (at nominal power)

MOTOR CONNECTION

Voltage.....	0..V _{1in} /V _{3in}
Frequency.....	0...300 Hz 0...120 Hz with dV/dT Filters
Motor Control.....	ABB Direct Torque Control Software Static Accuracy: 10% of Motor Slip
Speed Control.....	Dynamic Accuracy: 0.3-0.4% second with 100% Torque Step

Relay Outputs (3) Configurable.....	Form-C Switchover Contact 24 VDC or 250 VAC 2A max continuous current
Reference Voltage..... Output	10 VDC ± 0.5% 10mA max current
Auxiliary Voltage Output...	24 VDC ±10% 250 mA max current output

ENVIRONMENTAL LIMITS

Enclosures.....	NEMA 1/IP21 NEMA 12/IP54
Temperature.....	5...104° F (-15 to 40°C) Standard 104..122° F (40-50 C) with de-rating (1%/1 C)
Humidity.....	5...95% Relative Humidity
Altitude.....	0...3300 Ft (0...1000M) Standard 3300..13,123Ft (1000..4000M) with de-rating (1%/100M)
Vibration.....	Max. 1 mm (0.04 in.) 5-13.2 HZ Max. 7 m/s ² (23 ft/s ²) 13.2 – 100 HZ, Sinusoidal
Shock, Free Fall	Not Allowed

DRIVE PROTECTION

Keypad Failure Earth Fault Over Voltage Over Temperature (VFD) Phase Loss	Over Current Under Voltage Over Temperature (Motor) Over Torque Motor Stall
---	---

PUMP PROTECTION

Loss of Suction/Dry Run Low Flow Run-out Flow Shut-off/Dead Head Critical Speed Lockout	General Condition Sleep Function Sensor Failure Safe Speed Operation
---	---

FEATURES:

Smartflow Smartcontrol (PID Torque) Cavitation Control Automatic Fault Reset	Multipump (Synchronous Control) Multipump (Backup) System Curve Compensation Pump Cleaning Sequence
---	--

STANDARD INPUT/OUTPUT

2 Current Analog Inputs.....	4...20mA 100Ω Input Resistance 11 bit resolution
1 Voltage Analog Input.....	2-10 VDC 200Ω Input Resistance 11 bit resolution Galvanically isolated as a group

FIELDBUS

Communication Modules.....	Modbus, Profibus DP Ethernet, DeviceNet ControlNet
-------------------------------	--

Certified for Construction Purposes only when signed Date.....	Customer Name.....
	Goulds S/N.....
	Customer P.O #.....
	Item No.....