



**PumpSmart PS200  
Drive Dimensions and Ratings  
Frame R8-IP21/ACS800-02  
(Without Enclosure Extension)**

**PUMPSMART**

**PumpSmart PS200 Pump and Motor Control System**

The PumpSmart PS200 is a pump and motor control system that provides integral starting, right-sizing, pump protection and process control for all pumping applications. The PumpSmart PS200 is based upon the ABB ACS800 variable frequency drive platform. PumpSmart Control Solutions has worked with ABB to incorporate proprietary pump protection, process control and configuration algorithms into the drive to make it more suitable for pumping applications

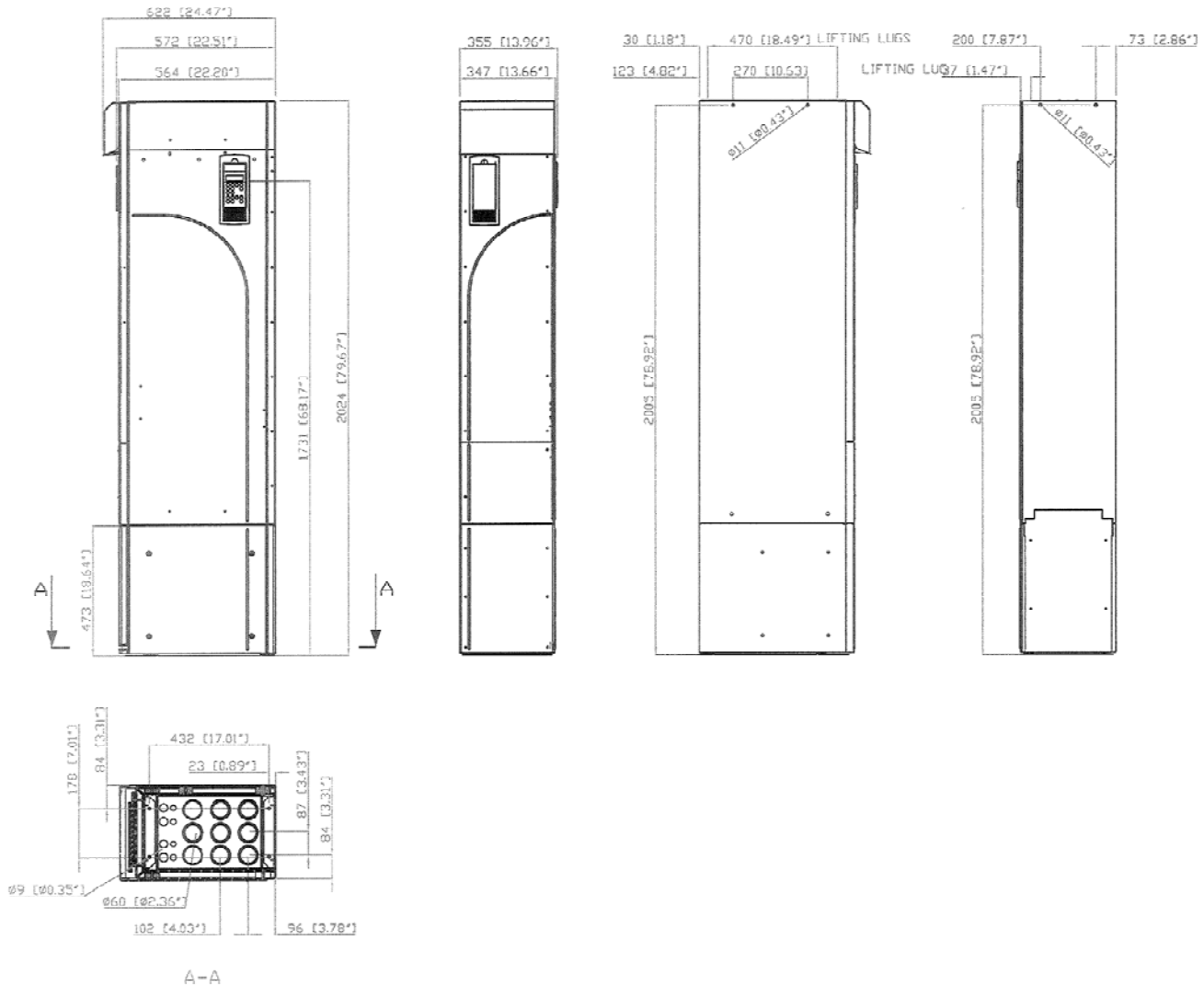

**Drive Dimensions**

| Frame | Height<br>mm<br>[inches] | Width<br>mm<br>[inches] | Depth<br>mm<br>[inches] | Weight<br>kg<br>[lbm] |
|-------|--------------------------|-------------------------|-------------------------|-----------------------|
| R8    | 2024<br>[79.69]          | 347<br>[13.66]          | 622<br>[24.47]          | 240<br>[529]          |

\*Dimensions not for construction



**PumpSmart PS200**  
**Drive Dimensions and Ratings**  
**Frame R8-IP21/ACS800-02**  
 (without Enclosure Extension)

**PUMPSMART**

**Drive Ratings**

| ITT Type Code     | Input Voltage VAC | Power P <sup>N1</sup> KW | Nominal Current I <sub>2N2</sub> Amps | Heat Dissipation Watts | Air Flow M <sup>3</sup> /Hr | Noise Level dBA | Frame | Enclosure Rating | Recommended Main Fuses |     |          |
|-------------------|-------------------|--------------------------|---------------------------------------|------------------------|-----------------------------|-----------------|-------|------------------|------------------------|-----|----------|
|                   |                   |                          |                                       |                        |                             |                 |       |                  | gG/aR                  | V   | IEC Size |
| ACS-ITT-02-0140-2 | 230               | 110                      | 396                                   | 5300                   | 1220                        | 72              | R8    | IP21             | 500/800                | 500 | 3        |
| ACS-ITT-02-0170-2 | 230               | 132                      | 440                                   | 6100                   |                             |                 |       |                  | 500/800                |     | 3        |
| ACS-ITT-02-0210-2 | 230               | 160                      | 516                                   | 6700                   |                             |                 |       |                  | 630/1000               |     | 3        |
| ACS-ITT-02-0230-2 | 230               | 160                      | 598                                   | 7600                   |                             |                 |       |                  | 630/1250               |     | 3        |
| ACS-ITT-02-0260-2 | 230               | 200                      | 679                                   | 7850                   |                             |                 |       |                  | 800/1400               |     | 3        |
| ACS-ITT-02-0300-2 | 230               | 200                      | 704                                   | 8300                   |                             |                 |       |                  | 800/1400               |     | 3        |
| ACS-ITT-02-0260-3 | 400               | 200                      | 440                                   | 6600                   |                             |                 |       |                  | 500/800                |     | 3        |
| ACS-ITT-02-0320-3 | 400               | 250                      | 516                                   | 7150                   |                             |                 |       |                  | 630/1000               |     | 3        |
| ACS-ITT-02-0400-3 | 400               | 315                      | 590                                   | 8100                   |                             |                 |       |                  | 630/1250               |     | 3        |
| ACS-ITT-02-0440-3 | 400               | 355                      | 679                                   | 8650                   |                             |                 |       |                  | 800/1400               |     | 3        |
| ACS-ITT-02-0490-3 | 400               | 400                      | 704                                   | 9100                   |                             |                 |       |                  | 800/1400               |     | 3        |
| ACS-ITT-02-0320-5 | 500               | 250                      | 435                                   | 6850                   |                             |                 |       |                  | 500/800                |     | 3        |
| ACS-ITT-02-0400-5 | 500               | 315                      | 510                                   | 7800                   |                             |                 |       |                  | 630/1000               |     | 3        |
| ACS-ITT-02-0440-5 | 500               | 355                      | 545                                   | 7600                   |                             |                 |       |                  | 630/1250               |     | 3        |
| ACS-ITT-02-0490-5 | 500               | 400                      | 590                                   | 8100                   |                             |                 |       |                  | 630/1250               |     | 3        |
| ACS-ITT-02-0550-5 | 500               | 450                      | 670                                   | 9100                   |                             |                 |       |                  | 800/1400               |     | 3        |
| ACS-ITT-02-0610-5 | 500               | 500                      | 704                                   | 9700                   |                             |                 |       |                  | 800/1400               | 3   |          |
| ACS-ITT-02-0320-7 | 690               | 250                      | 290                                   | 6150                   |                             |                 |       |                  | 315/630                | 2   |          |
| ACS-ITT-02-0400-7 | 690               | 315                      | 344                                   | 6650                   |                             |                 |       |                  | 400/630                | 3   |          |
| ACS-ITT-02-0440-7 | 690               | 355                      | 387                                   | 7400                   |                             |                 |       |                  | 500/800                | 3   |          |
| ACS-ITT-02-0490-7 | 690               | 400                      | 426                                   | 8450                   |                             |                 |       |                  | 500/900                | 3   |          |
| ACS-ITT-02-0550-7 | 690               | 450                      | 482                                   | 8300                   |                             |                 |       |                  | 500/900                | 3   |          |
| ACS-ITT-02-0610-7 | 690               | 500                      | 537                                   | 9750                   |                             |                 |       |                  | 630/1000               | 3   |          |

<sup>1</sup> P<sub>N</sub> - Nominal Power Rating at listed voltage rating for variable torque loads  
<sup>2</sup> I<sub>2N</sub> - Continuous base current with 10% overload for 1 min / 5 minutes at 40° C

| Frame Size | U1/V1/W1 - U2/V2/W2<br>BRK ±UDC±Terminals |            |       |        | Earthing PE Terminal |        |
|------------|---|------------|-------|--------|----------------------|--------|
|            | Holes Per Phase                           | Cable Dia. | Screw | Torque | Screw                | Torque |
|            |   | mm         |       | Nm     |                      | Nm     |
| R 8        | 3   | 58         | M12   | 50..75 | M8                   | 15..22 |

The maximum allowed width of cable lug is 38 mm

**General Notes:**

- 360° Grounded terminations are required
  - Select either gG or aR fuses depending on installation design.
- Refer to Technical Data section for details

**Power Cabling Schematic**

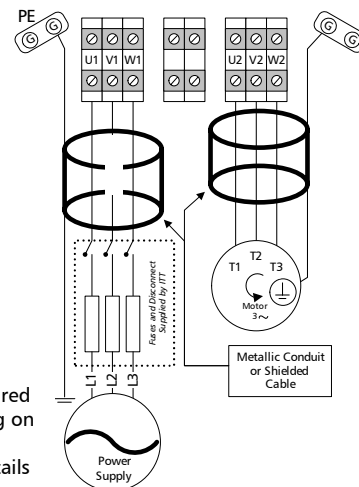



**PumpSmart PS200**  
**Drive Dimensions and Ratings**  
**Frame R8-IP21/ACS800-02**  
**(Without Enclosure Extension)**

**PUMPSMART**

**PumpSmart® PS200**

Drive Hardware: ABB ACS800 -6 Pulse PWM

**CERTIFICATIONS**

USA/Canada  
 600 VAC and Below  
 UL, C-UL, CSA

Europe  
 CE Marked  
 Bureau Veritas Cert 14370/AO BV  
 EMC 89/336/EEC as amended by 93/68  
 DNV Cert. E-7039

2 Current Analog

Output.....

4...20mA  
 700Ω Max load impedance  
 10 bit resolution  
 Galvanically isolated as a group

**INPUT POWER**

Voltage..... 208..690 VAC 3 Phase ±10%  
 Overload..... 110% for 1 min/5 min,  
 140-150% for 10 sec at startup  
 Frequency..... 48..63Hz

Digital Inputs (7).....

2 Wire Start/Stop  
 Hand-off Auto (HOA)  
 3-Wire Start/Stop  
 Setpoint 1-2  
 Speed Override  
 Specific Gravity  
 Secondary Protect A/B  
 Digital Reset  
 E Stop/Permissive  
 Motor Thermistor  
 24 VDC Input Voltage  
 1 mS filtering time

Fundamental Power.....  $\text{COS}\Phi_1 = 0.98$  (fundamental)  
 Factor ( $\text{COS}\Phi_1$ )  $\text{COS}\Phi_1 = 0.93..95$  (total)  
 Efficiency..... 98% (at nominal power)

**MOTOR CONNECTION**

Voltage.....  $0..V_{1in}/V_{3in}$   
 Frequency..... 0...300 Hz  
 0...120 Hz with dV/dT Filters  
 Motor Control..... ABB Direct Torque Control Software  
 Static Accuracy: 10% of Motor Slip  
 Speed Control..... Dynamic Accuracy: 0.3-0.4% second  
 with 100% Torque Step

Relay Outputs (3)

Configurable.....

Form-C Switchover Contact  
 24 VDC or 250 VAC  
 2A max continuous current

Reference Voltage.....  
 Output

10 VDC ± 0.5%  
 10mA max current

Auxiliary Voltage Output...

24 VDC ±10%  
 250 mA max current output

**ENVIRONMENTAL LIMITS**

Enclosures..... NEMA 1/IP21  
 NEMA 12/IP54  
 Temperature..... 5...104° F (-15 to 40°C) Standard  
 104..122° F (40-50 C) with  
 de-rating (1%/1 C)  
 Humidity..... 5...95% Relative Humidity  
 Altitude..... 0...3300 Ft (0...1000M) Standard  
 3300..13,123Ft (1000..4000M) with  
 de-rating (1%/100M)  
 Vibration..... Max. 1 mm (0.04 in.) 5-13.2 HZ  
 Max.  $7 \text{ m/s}^2$  ( $23 \text{ ft/s}^2$ ) 13.2 – 100  
 HZ, Sinusoidal  
 Shock, Free Fall ..... Not Allowed

**DRIVE PROTECTION**

Keypad Failure  
 Earth Fault  
 Over Voltage  
 Over Temperature (VFD)  
 Phase Loss  
 Over Current  
 Under Voltage  
 Over Temperature (Motor)  
 Over Torque  
 Motor Stall

**PUMP PROTECTION**

Loss of Suction/Dry Run  
 Low Flow  
 Run-out Flow  
 Shut-off/Dead Head  
 Critical Speed Lockout  
 General Condition  
 Sleep Function  
 Sensor Failure  
 Safe Speed Operation

**FEATURES:**

Smartflow  
 Smartcontrol (PID Torque)  
 Cavitation Control  
 Automatic Fault Reset  
 Multipump (Synchronous Control)  
 Multipump (Backup)  
 System Curve Compensation  
 Pump Cleaning Sequence

**STANDARD INPUT/OUTPUT**

2 Current Analog Inputs..... 4...20mA  
 100Ω Input Resistance  
 11 bit resolution  
 1 Voltage Analog Input..... 2-10 VDC  
 200Ω Input Resistance  
 11 bit resolution  
 Galvanically isolated as a group

**FIELDBUS**

Communication  
 Modules.....  
 Modbus, Profibus DP  
 Ethernet, DeviceNet  
 ControlNet

|   |  |
|---|--|
| Certified for Construction Purposes only when signed<br><br><br><br><br>Date..... | Customer Name.....<br><br>Goulds S/N.....<br><br>Customer P.O #.....<br><br>Item No..... |
|---|--|